

UNITED STATES PATENT AND TRADEMARK OFFICE

BEFORE THE PATENT TRIAL AND APPEAL BOARD

GARMIN INTERNATIONAL, INC. ET AL.
Petitioner

v.

Patent of CUOZZO SPEED TECHNOLOGIES LLC
Patent Owner

Case IPR2012-00001 (JL)
Patent 6,778,074

Before MICHAEL P. TIERNEY, *Lead Administrative Patent Judge*, JAMESON LEE and JOSIAH COCKS, *Administrative Patent Judges*.

LEE, *Administrative Patent Judge*.

DECISION TO INITIATE
TRIAL FOR INTER PARTES REVIEW

BACKGROUND

Petitioner Garmin International Inc. et al. requests inter partes review of claims 1-20 of US Patent 6,778,074 ('074 Patent) pursuant to 35 U.S.C. §§ 311 et seq. The Patent Owner, Cuozzo Speed Technologies LLC., has waived its right to

file a preliminary response under 37 C.F.R. § 42.107(b). (Paper 10). We have jurisdiction under 35 U.S.C. § 314.

The standard for instituting inter partes review is set forth in 35 U.S.C. § 314(a) which provides:

THRESHOLD -- The Director may not authorize an inter partes review to be instituted unless the Director determines that the information presented in the petition filed under section 311 and any response filed under section 313 shows that there is a reasonable likelihood that the petitioner would prevail with respect to at least 1 of the claims challenged in the petition.

Petitioner challenges the patentability of claims 1-20 on the basis of the following items of prior art:

US 6,633,811 (Aumayer)	October 14, 2003	Ex. 1001
US 6,515,596 (Awada)	February 4, 2003	Ex. 1010
German DE 19755470 A1 (Tegethoff) English Translation of Tegethoff	September 24, 1998	Ex. 1002 Ex. 1003
JP H07-182598 (Hamamura) English Translation of Hamamura	July 21, 1995	Ex. 1006 Ex. 1007
US 5,375,043 (Tokunaga)	December 20, 1994	Ex. 1005
US 3,980,041 (Evans)	September 14, 1976	Ex. 1009
US 2,711,153 (Wendt)	June 21, 1955	Ex. 1011

In this opinion, citations to Tegethoff and Hamamura are made with respect to their respective English translations noted above.

Petitioner expressly asserts these grounds of unpatentability:

1. Claims 1, 2, 6, 7, 8, 9, 10, 11, 12, 13, 18, 19, and 20 are unpatentable under 35 U.S.C. § 102(e) as anticipated by Aumayer.
2. Claims 1, 2, 6, and 7 are unpatentable under 35 U.S.C. § 102(b) as anticipated by Tegethoff.

3. Claim 1 is unpatentable under 35 U.S.C. § 102(b) as anticipated by Tokunaga.
4. Claims 3, 4, 5, 14, 15, and 16 are unpatentable under 35 U.S.C. § 103 as obvious over Aumayer and Evans.
5. Claim 17 is unpatentable under 35 U.S.C. § 103 as obvious over Aumayer, Evans, and Wendt.
6. Claims 3, 4, and 5 are unpatentable under 35 U.S.C. § 103 as obvious over Tegethoff and Evans.
7. Claims 8, 9, 10, 11, 12, 13, 18, 19, and 20 are unpatentable under 35 U.S.C. § 103 as obvious over Tegethoff and Awada.
8. Claims 14, 15, and 16 are unpatentable under 35 U.S.C. § 103 as obvious over Tegethoff, Awada, and Evans.
9. Claim 17 is unpatentable under 35 U.S.C. § 103 as obvious over Tegethoff, Awada, Evans, and Wendt.
10. Claims 10 and 20 are unpatentable under 35 U.S.C. § 103 as obvious over Tokunaga and Hamamura.

DISCUSSION

Our decision hinges on the meaning of “integrally attached” in independent claims 1 and 10.

Claim Construction

Consistent with the statute and the legislative history of the AIA, the Board interprets claim terms by applying the broadest reasonable construction in the context of the specification in which the claims reside. 37 C.F.R. § 42.100(b); *see* Office Patent Trial Practice Guide, 77 Fed. Reg. 48756, 48766 (Aug. 14, 2012).

Also, we give claim terms their ordinary and accustomed meaning as would be understood by one of ordinary skill in the art. *Phillips v. AWH Corp.*, 415 F.3d 1303, 1326 (Fed. Cir. 2005)(en banc). That ordinary and accustomed meaning applies unless the inventor as a lexicographer has set forth a special meaning for a term. *Multiform Desiccants, Inc. v. Medzam, Ltd.*, 133 F.3d 1473, 1477 (Fed. Cir. 1998); *York Prods., Inc. v. Central Tractor Farm & Family Ctr.*, 99 F.3d 1568, 1572 (Fed. Cir. 1996). When an inventor acts as a lexicographer, the definition must be set forth with reasonable clarity, deliberateness, and precision. *Renishaw PLC v. Marposs Societa per Azioni*, 158 F.3d 1243, 1249 (Fed. Cir. 1998).

If we need not rely on a feature to give meaning to what the inventor means by a claim term, that feature would be “extraneous” and should not be read into the claim. *Renishaw PLC*, 158 F.3d at 1249. The construction that stays true to the claim language and most naturally aligns with the inventor’s description is likely the correct interpretation. *See Id.*, 158 F.3d at 1254.

In some cases, the ordinary meaning of claim language as understood by a person of skill in the art may be readily apparent even to lay judges, and claim construction in such cases involves little more than the application of the widely accepted meaning of commonly understood words. *Phillips v. AWH Corp.*, 415 F.3d at 1314. In this case, Petitioner sets forth no claim construction that is purportedly different between that from the perspective of one with ordinary skill in the art on the one hand and that of lay persons on the other. We have no basis to think differently and to conclude otherwise. So for purposes of this decision we proceed on the basis that the plain and ordinary meaning of words in their common usage applies, albeit taken in the context of the disclosure of the ‘074 Patent.

The Invention of the '074 Patent

The disclosed invention of the '074 Patent is directed to a speed limit indicator and method for displaying speed and the relevant speed limit for use in connection with vehicles. (Spec. 1:9-11). Specifically, the speed indicator displays the current speed of a vehicle and how it relates to the legal speed limit for the current location in which the vehicle is traveling. (Spec. 1:13-16). It provides the benefit of eliminating the need for the driver to take eyes off the road to look for speed limit signs and to resolve any confusion that might exist as to what is the current legal speed limit. (Spec. 1:22-25).

Figure 1 illustrates the specifically disclosed embodiment:

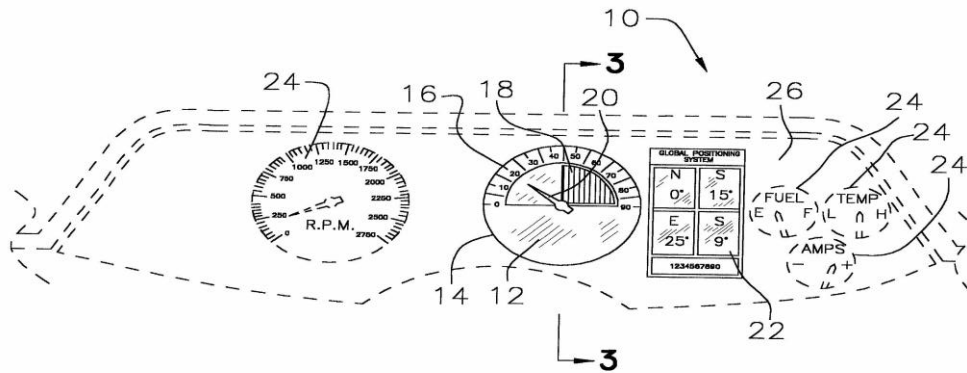

FIG. 1

Figure 1 illustrates a specifically disclosed embodiment

Speedometer 12 is mounted on dashboard 26. (Spec. 5:8-9). Speedometer 12 has a backplate 14 made of plastic, speed denoting markings 16 painted on backplate 14, a colored display 18 made of red plastic filter, and a plastic needle 20 rotatably mounted in the center of backplate 14. (Spec. 8-11). A global positioning receiver 22 is positioned adjacent to speedometer 12 and other gauges typically present on a vehicle dashboard 26 are included. (Spec. 5:13-15).

Referring to a flowchart provided in Figure 2 with numerical references to individual steps and not individual parts, the specification of the '074 Patent describes operation of the speed limit indicator as follows (Spec. 5:25-39):

Uploading unit 38 uploads current data to a regional speed limit database 40. The global positioning system receiver 42 tracks the vehicle's location and speed, and identifies the relevant speed limit from the database for that location. The global positioning system receiver compares the vehicle's speed and the relevant speed limit 44, and uses a tone generator 46 to generate a tone in the event that the vehicle's speed exceeds the relevant speed limit. The speed limit information is sent from the global positioning system receiver to a filter control unit 48. **The control unit adjusts the color filter so that the speeds above the legal speed limit are displayed in red 50 while the legal speeds are displayed in white 52. This is accomplished by the control unit rotating the red filter disc 54 to the appropriate degree.** (Emphasis added.)

Claims 1 and 10 are the only independent claims. Claim 1 is reproduced below:

1. A speed limit indicator comprising:
 - a colored display to delineate which speed readings are in violation of the speed limit at a vehicle's current location;
 - a speedometer **integrally attached** to said colored display; and
 - a display controller connected to said colored display, wherein said display controller adjusts said colored display independently of said speedometer to continuously update the delineation of which speed readings are in violation of the speed limit at a vehicle's present location. (Emphasis added.)

Claim 1 requires that the speedometer be "integrally attached" to the colored display. Claim 10 is the same, as it also recites: "a speedometer integrally attached to said colored display."

Claim 20 is reproduced below:

20. A method of determining speed, the relevant speed limit, and displaying same, which comprises the steps of:

uploading current information to regional speed limit database;

determining vehicle location and speed;

obtaining speed limit for said vehicle location from said database;

comparing vehicle speed to said speed limit;

generating tone if said vehicle speed exceeds said speed limit;

sending speed limit to display control unit; and

modifying **the limit indicator as defined in claim 1** to reflect which speeds are below said speed limit and which speeds exceed said speed limit. (Emphasis added.)

In its last clause, claim 20 specifically refers to the structure of the speed limit indicator of claim 1. Thus, claim 20 is dependent on claim 1 and also includes the limitation that the speedometer is integrally attached to the colored display. Petitioner has not taken any contrary position in the Petition.

Petitioner does not make known its construction of “integrally attached.” Instead, Petitioner states that the term has to mean, in this proceeding, what the Patent Owner asserts it means in the infringement suits the Patent owner has filed against various parties including Petitioner. That argument is without merit. The meaning of claim terms is not governed by what the Patent Owner says they mean in filing an infringement suit based on the '074 Patent. There is no reason to assume that the Patent Owner's litigation position is correct. Litigation positions taken subsequent to issuance of the patent are unreliable. *See Phillips v. AWH*

Corp., 415 F.3d at 1318. In any event, the Petition itself does not disclose or discuss the Patent Owner's position and Petitioner even states that the Patent Owner's litigation position in the infringement suits is not necessarily correct. (Petition 18: n.1).

On this record, we construe "integrally attached" as applied to the colored display and the speedometer in the context of the disclosure of the '074 Patent as meaning that the two elements are discrete parts physically joined together as a unit without each part losing its own separate identity. In the combined unit, the colored display is still the colored display and the speedometer is still the speedometer; each retains its own separate identity. The specification of the '074 Patent discloses that colored display 18 is a separate item from backplate 14 and from speed denoting marking 16 on backplate 14. ('074 Patent 5:9-12). Claim 1 even expressly recites that the display controller adjusts the colored display independently of the speedometer. In that connection, we note further that Patent Owner's amendment in the prosecution history of the '074 Patent, dated January 9, 2004, states (Ex. 1013 7:23-25):

Support for the amendment to specify that the speedometer is integrally attached to the colored display is found in the specification at p.7, lines 28-30, p.8, lines 21-23, and in Fig. 1, 3, and 4.

The above-quoted portions of the specification describe speedometer backplate 14 and speed denoting markings 16 painted on backplate 14 as separate and discrete elements from the colored display 18. Petitioner has not presented a reasonable basis to broaden out the interpretation of "integrally attached" to cover the case of a single electronic display that itself operates both as a speedometer and a colored display. The Patent Owner relied on separate components as providing written description support for the term.

Aumayer

Aumayer discloses a method for displaying vehicle speed. (Abstract:1-2). Also, the speed limit at the current location may be displayed on a speed scale by highlighting a scale mark or producing a scale mark of a different length or color. (Abstract:9-12). The current location of the vehicle is determined by use of a GPS locating device. (Aumayer 4:41-45). The speed limit at the current location of the vehicle is retrieved from a data storage media according to the determined current location. (Abstract:13-15; Aumayer 4:45-53). Aumayer also describes (Aumayer 7:34-37):

The display device 211 comprises a display controller and a display medium, for example a display screen provided by **a liquid crystal display device, a plasma screen or a cathode ray tube**. (Emphasis added.)

Figure 2d of Aumayer is reproduced below, which illustrates an electronic display according to practicing Aumayer's disclosed method:

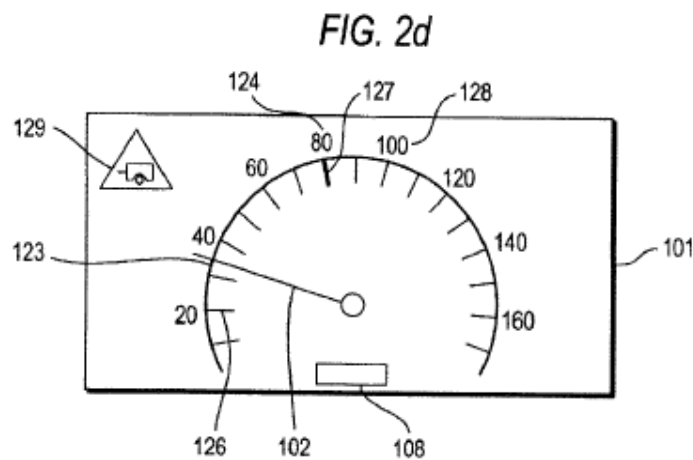

Figure 2d shows a display according to Aumayer's method

With respect to Figure 2d, Aumayer describes that the determined speed limit of 80 km/hr for the vehicle's current location is shown by the speed scale value 124 and speed scale mark 127 at the speed limit, both of which are highlighted or emphasized such as by use of color different from that used for the remainder of the display device, by enlargement, and/or by widening, on the electronic display. (Aumayer 6:21-27). Aumayer expressly states that the speed limit is highlighted or emphasized by the scale mark 127. (Aumayer 6:33-35).

Aumayer further states that "it is also possible to use a commercial combined apparatus with mechanical display elements for the display device 211." (Aumayer 7:42-44). Specific details of that mechanical embodiment are not described. However, Aumayer states that for example, "a speed limit can be made visible by background lighting in a different color at the scale mark associated with the corresponding speed limit." (Aumayer 7:48-51).

Tegethoff

Tegethoff discloses an image display system for use on a vehicle, which includes an image screen and an image generating computer. (Tegethoff 4:2:16-18). The image displayed on the screen mimics that of analog mechanical pointer instruments, and in their outer image form cannot be distinguished from purely mechanical devices. (Tegethoff 4:2:34-40). Figure 2 of Tegethoff is reproduced below, which illustrates an image of a speedometer and other useful information (Tegethoff 5:2:30-32):

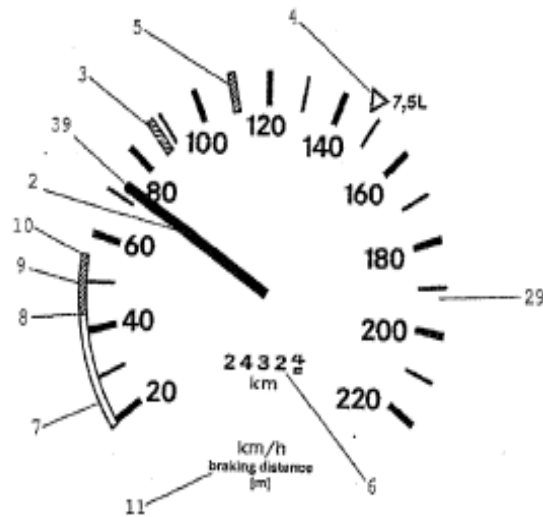

Fig. 2

Figure 2 shows an embodiment of Tegethoff's image display

On the image shown above is displayed a mark 5 for indicating a currently permissible maximum speed for the road section where the vehicle is currently located. (Tegethoff 6:1:9-12). According to Tegethoff, that speed limit can be set according to an element for navigation and a database. (Tegethoff 6:1:13-15). Tegethoff describes that the critical markings such as that showing the speed limit can be colored red. (Tegethoff 7:1:38-45).

Tokunaga

Tokunaga discloses a lighting unit capable of varying the luminescence and color of illumination with respect to a target to be lit thereby to provide an effective display of the target, and capable of itself serving as a display unit. (Abstract 1-5). Tokunaga discloses two embodiments of the lighting unit, one shown in Figure 1 and one shown in Figure 3:

FIG. 1

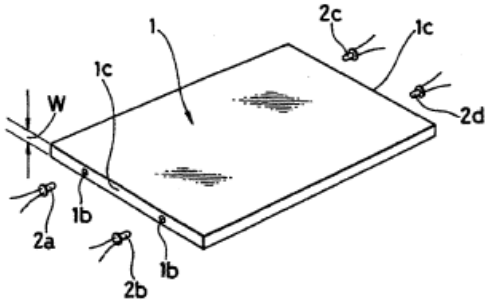
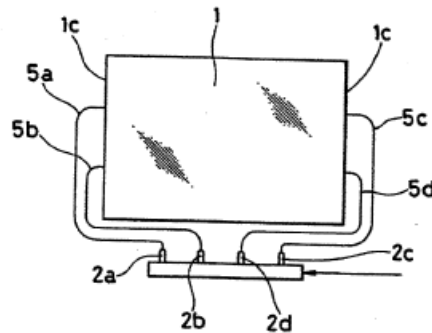

FIG. 3



Figures 1 and 3 illustrate separate embodiments of a lighting unit

In both embodiments, there is a light guide plate 1. In the Figure 1 embodiment, LEDs 2a-2d are directly fitted to the side edges of the light guide plate, and in the Figure 3 embodiment, LEDs 2a-2d are indirectly provided to the side edges of the light guide plate 1 through optical transmission media such as optical fibers 5a-5d. (Tokunaga 2:12-22). The light guide plate 1 is suitable for use as a backlight for a liquid crystal display panel on a portable electronic device. (Tokunaga 2:37-41). Figure 2 shows the light guide plate 1 disposed next to a liquid crystal display panel:

FIG. 2

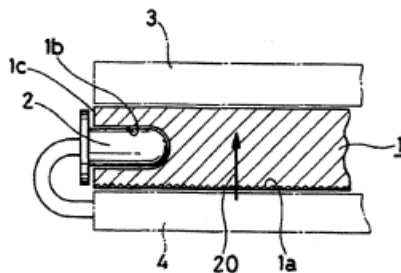

Figure 2 illustrates a partial sectional view of light guide plate 1

Tokunaga describes that a liquid crystal display panel 3 is disposed on top of the light guide plate 1 so as to permit the content of the liquid crystal display to be irradiated with light sent from the light guide plate 1, and that under the light guide plate 1 there is an electronic circuit board 4 for operating the liquid crystal display panel. (Tokunaga 2:66 to 3:5). Tokunaga describes that the lighting unit can be used to illuminate the liquid crystal display panel of a portable electronic game machine such as GAME BOY[®]. (Tokunaga 3:54-59). Tokunaga also describes that the liquid crystal display panel of the game machine is operated according to image signals from an operation circuit and the light guide plate 1 is incorporated into the game machine to illuminate the liquid crystal display. (Tokunaga 3:63-68).

Tokunaga does not, however, describe specifically how the light guide plate 1 is put in position relative to liquid crystal display panel 3 or electronic circuit board 4. It is known only that the light guide plate 1 is incorporated into the overall game machine, that the liquid crystal display is disposed on one side, and that the electronic circuit board is disposed on the opposing side as shown in Figure 2.

Tokunaga further states that although the description of the lighting unit provided in the disclosure is made by way of example in the context of a game machine, it would be obvious to those of ordinary skill in the art that the lighting unit has other applications such as illuminating the display surfaces of a vehicle speedometer. (Tokunaga 4:62-67). However, the statement of potential application elsewhere is only general and Tokunaga does not describe any specific structural implementation of the application of the lighting unit to a vehicle speedometer. Tokunaga does state that in the case of application to a vehicle speedometer, the color of the display light for the speedometer can be changed

from blue to red if the vehicle speed exceeds a legal speed limit. (Tokunaga 5:1-5). But it does not describe that the “legal speed limit” it refers to is one associated specifically to the current location of the vehicle.

A. The alleged grounds based in whole or in part on Aumayer

Each of independent claims 1 and 10 requires that the speedometer be “integrally attached” to the colored display. According to the petitioner, a single liquid crystal display screen such as that of Aumayer’s display device 211, which displays the image of both the speedometer and the colored scale mark 107 showing the speed limit, satisfies the claim requirement of an integral attachment between a speedometer and a colored display. (Petition 18:1-4).

For reasons already discussed above, on this record we construe “integrally attached” differently from the Petitioner. The single electronic display screen of Aumayer showing both the image of a speedometer and a colored scale mark indicating the current speed limit does not meet the claim recitation “integrally attached” as applied to a speedometer and a colored display. There, the speedometer and the colored display are not discrete and separately recognizable parts that are “integrally attached” to each other. Rather, the liquid crystal display screen is itself a single component which performs the function of both the speedometer and colored display.

We recognized already that Aumayer states that “it is also possible to use a commercial combined apparatus with mechanical display elements for the display device 211.” (Aumayer 7:42-44). We also already recognized that Aumayer states that “a speed limit can be made visible by background lighting in a different color at the scale mark associated with the corresponding speed limit.” (Aumayer 7:48-51). None of that disclosure indicates that a colored display is necessarily integrally attached to the speedometer. No specific embodiment of a combined

apparatus with mechanical display elements is described in sufficient detail. Even Petitioner has not explained how such general disclosure meets the requirement of “integrally attached” between the speedometer and the colored display.

A claim is anticipated only if each and every element as set forth in the claim is found, either expressly or inherently, in a single prior art reference *Verdegaal Bros., Inc. v. Union Oil Co. of Cal.*, 814 F.2d 628, 631 (Fed. Cir. 1987).

Claims 2, 6-13, and 18-20 each depend directly or indirectly from either claim 1 or claim 10. Because Aumayer fails to disclose the “integrally attached” element of claims 1 and 10 as applied to the speedometer and the colored display, there is not a reasonable likelihood that the Petitioner would prevail on its assertion that claims 1, 2, 6-13, and 18-20 are anticipated by Aumayer under 35 U.S.C. § 102(e).

The above-noted deficiency of Aumayer with respect to independent claim 1 undermines Petitioner’s assertion of obviousness of claims 4 and 5 over Aumayer and Evans under 35 U.S.C. § 103. Claim 4 depends on claim 1 and claim 5 depends on claim 4. Claims 4 and 5 recite the specific mechanical structure of a speedometer, such as a needle, an axle, and a cable (claim 4), and a backplate and a housing (claim 5). As applied by Petitioner to claims 4 and 5, Evans discloses all of those elements but does not cure the above-noted deficiency of Aumayer discussed in the context of independent claim 1 with regard to a colored display being “integrally attached” to the speedometer. There is not a reasonable likelihood that the petitioner would prevail on its assertion that claims 4 and 5 would have been obvious over Aumayer and Evans under 35 U.S.C. § 103.

Petitioner also asserts that claims 3 and 14-16 would have been obvious over Aumayer and Evans, and that claim 17 would have been obvious over Aumayer, Evans, and Wendt, under 35 U.S.C. § 103. As applied by Petitioner to claims 3

and 14-16, Evans does seemingly disclose what Aumayer does not disclose, *i.e.*, a colored display which is “integrally attached” to the speedometer. However, the above-noted deficiency of Aumayer is not cured by Petitioner’s reliance on Evans because Petitioner has not articulated a credible rationale for combining the teachings of Aumayer and Evans to arrive at the claimed invention.

Aumayer discloses an embodiment including each of the recited elements of independent claims 1 and 10 of the ’074 Patent, except for the requirement that the speedometer and the colored display are “integrally attached.” Claim 3 depends on claim 1 and recites that the colored display is a colored filter. Claim 14 depends on claim 10 and also recites that the colored display is a colored filter. Claim 15 depends on claim 14 and claim 16 depends on claim 15.

Evans discloses a combined vehicle speedometer and speed warning indicator. (Evans 1:68 to 2:23). The speed warning indicator is installed on the speedometer cover. (Evans 2:16-17). It comprises a transparent plate attached to the transparent front cover of the speedometer. (Evans 2:1-3). Evans describes the speed warning indicator as follows (Evans 2:3-8):

The plate bears warning indicia, for example, **a special color** and/or a plurality of marks, spaces, ridges, etc. so that when the speedometer dial is viewed through it, a portion of the dial representing speeds in excess of a predetermined limit are demarked by the warning indicia. (Emphasis added.)

Evans describes that a driver can tell what speeds are under or in excess of the speed limit by making a swift reference to the speedometer through the indicator and see whether the speedometer needle is in or out of the warning area on the indicator plate. (Evans 2:9-13). Evans further describes that the indicator plate can be made adjustable for changes in the speed limit. (Evans 2:18-19). As shown in Figure 3, the red colored plate 12 is positioned on speed dial 30 so that

only the portion of the dial which contains numbers representing speeds in excess of the speed limit is overlaid by the plate:

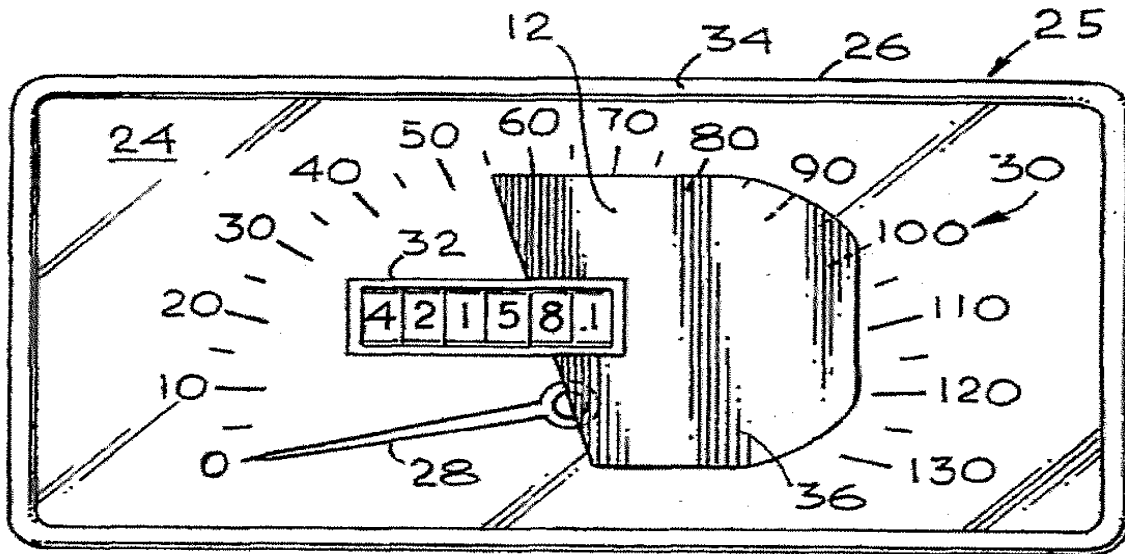

Fig. 3

Figure 3 illustrates a front elevation view of the combined speedometer and speed warning indicator

The colored filter plate 12 of Evans is a fixed structure integrally attached to the speedometer. However, although the plate may be removed and replaced, in its operational state it is a fixed, non-moveable, and non-adjustable structure. In that connection, Evans states (Evans 3:37-44):

It will be understood that plate 12 can, if desired, be removed from cover 24 and either another similar plate of different configuration can be substituted or plate 12 can be recut and repositioned or merely repositioned on cover 24 so as to extend over another range of speed numbers on dial 30. For example this would be desirable in the event that the 55 mph current speed limit were abolished.

With regard to claims 3 and 14-16, Petitioner has not explained why one with ordinary skill in the art would have chosen to use the fixed and immovable colored plate 12 of Evans in combination with the dynamic display system of

Aumayer which provides the benefits of a continuously controlled and updated colored display to indicate the applicable speed limit for the vehicle at its current location.

Accordingly, there is not a reasonable likelihood that the petitioner would prevail on its assertion that claims 3 and 14-16 would have been obvious over Aumayer and Evans under 35 U.S.C. § 103.

Claim 17 depends on claim 14, and states that the display controller rotates the colored filter independently of the speedometer to continuously update the delineation of which speed readings are in violation of the speed limit at a vehicle's present location. For claim 17, Petitioner relies on Wendt in combination with Aumayer and Evans. Wendt and Evans in combination seemingly cures the above-noted deficiency of Aumayer with regard to independent claim 10 and of Aumayer and Evans with regard to claim 14. That is because Wendt teaches the desirability of a rotatably moveable structure to indicate the speed limit.

The combined teachings of Aumayer, Evans, and Wendt appears to account for all the features of claim 17. Accordingly, there is a reasonable likelihood that the petitioner would prevail on its assertion that 17 would have been obvious over Aumayer, Evans, and Wendt under 35 U.S.C. § 103.

Because claim 17 depends on claim 14 which depends on claim 10, and because dependent claims include all of the features of the claims on which they depend, Petitioner also has shown a reasonable likelihood that it would prevail on demonstrating that claims 10 and 14 would have been obvious over the combined teachings of Aumayer, Evans, and Wendt. We recognize that Petitioner did not specifically articulate a ground of unpatentability against claims 10 and 14 based on Aumayer, Evans, and Wendt. However, we exercise discretion to recognize

that the assertion was implicitly made by Petitioner's alleging that claim 17 would have been obvious over Aumayer, Evans, and Wendt.

For claims 1-9, 11-13, 15, 16, and 18-20, we have not considered the ground of obviousness under 35 U.S.C. § 103, based on the combined teachings of Aumayer, Evans, and Wendt, and take no position in that regard. In this petition, that ground of obviousness has not been asserted by Petitioner against those claims, either expressly or by implication.

B. The alleged grounds based in whole or in part on Tegethoff

Each of independent claims 1 and 10 requires that the speedometer be "integrally attached" to the colored display. Tegethoff shares the same deficiency in that regard with Aumayer as discussed above. According to the Petitioner, a single digital electronic display screen 37 that displays the image of both the speedometer and the colored tick mark 5 showing the speed limit satisfies the claim requirement of an integral attachment between a speedometer and a colored display. (Petition 22:1-4).

For reasons already discussed above, on this record we construe "integrally attached" differently from the Petitioner. The single digital electronic display screen 37 of Tegethoff displaying both the image of a speedometer and a colored tick mark 5 indicating the current speed limit does not meet the claim recitation "integrally attached" as applied to a speedometer and a colored display. There, the speedometer and the colored display are not discrete and separately recognizable parts that are "integrally attached" to each other. Rather, the screen performs the function of both the speedometer and colored display.

Claims 2, 6, and 7 each depend directly from claim 1. Because Tegethoff fails to disclose the "integrally attached" element of claim 1 as applied to the speedometer and the colored display, there is not a reasonable likelihood that the

Petitioner would prevail on its assertion that claims 1, 2, 6, and 7 are anticipated by Tegethoff under 35 U.S.C. § 102(b).

The above-noted deficiency of Tegethoff with respect to independent claim 1 undermines Petitioner's assertion of obviousness of claims 4 and 5 over Tegethoff and Evans under 35 U.S.C. § 103. Claim 4 depends on claim 1 and claim 5 depends on claim 4. Claims 4 and 5 recite the specific mechanical structure of a speedometer, such as a needle, an axle, and a cable (claim 4), and a backplate and a housing (claim 5). As applied by Petitioner to claims 4 and 5, Evans discloses all of those elements but does not cure the above-noted deficiency of Tegethoff discussed in the context of independent claim 1 with regard to a colored display being "integrally attached" to the speedometer. There is not a reasonable likelihood that Petitioner would prevail on its assertion that claims 4 and 5 would have been obvious over Tegethoff and Evans under 35 U.S.C. § 103.

Petitioner also asserts that claim 3 would have been obvious over Tegethoff and Evans under 35 U.S.C. § 103. As applied by Petitioner to claim 3, Evans does disclose what Aumayer does not disclose, *i.e.*, a colored display which is "integrally attached" to the speedometer. However, the above-noted deficiency of Tegethoff is not cured by reliance on Evans because Petitioner has not articulated a credible rationale for combining the teachings of Tegethoff and Evans to arrive at the claimed invention. The deficiency is the same as that discussed above on the lack of sufficient basis to combine the teachings of Evans and Aumayer. We note again that the color filter of Evans is fixed and immovable. Tegethoff requires a colored display that is variable in position to reflect the current speed limit at the current location of the vehicle. Accordingly, there is not a reasonable likelihood that the Petitioner would prevail on its assertion that claim 3 would have been obvious over Tegethoff and Evans under 35 U.S.C. § 103.

As is the case with claim 1, with respect to claim 10 Tegethoff does not disclose the limitation of a speedometer integrally attached to a colored display. Petitioner's reliance on Awada in combination with Tegethoff does not cure that deficiency. Awada is relied on by the Petitioner in connection with claim 10 as teaching the use of a global positioning system connected to a display controller for providing signals for continuously updating the delineation of which speed readings are in violation of the speed limit at the vehicle's current location.

Claims 8, 9, and 20 each depend directly or indirectly on claim 1. Claims 11-13, 18, and 19 each depend directly or indirectly on claim 10. Petitioner relies on Awada in combination with Tegethoff as teaching the specific features added by these dependent claims. However, as applied by the Petitioner, Awada does not cure the deficiency of Tegethoff with respect to the limitation in independent claims 1 and 10 that the speedometer is integrally attached to the colored display. Thus, there is not a reasonable likelihood that the Petitioner would prevail on its assertion that claims 8-13, and 18-20 would have been obvious over Tegethoff and Awada under 35 U.S.C. § 103.

Claim 14 depends on claim 10 and recites that the colored display is a colored filter. Claim 15 depends on claim 14 and claim 16 depends on claim 15.

For claims 14-16, Petitioner relies on Evans as teaching the use of a colored filter that is attached to a speedometer. However, as is the case with Petitioner's attempted combination of Aumayer and Evans, already discussed above, Petitioner has not articulated a credible rationale to make the purported combination of Tegethoff and Evans. The colored filter of Evans is fixed and immovable during operation. Tegethoff, on the other hand, requires a colored display that can be variably adjusted while the vehicle is in motion, to match the applicable speed limit for the current location of the vehicle. Accordingly, there is not a reasonable

likelihood that the Petitioner would prevail on its assertion that claims 14-16 would have been obvious over Tegethoff, Awada, and Evans under 35 U.S.C. § 103.

Claim 17 depends on claim 14 and adds that the display controller rotates the colored filter independently of the speedometer to continuously update the delineation of which speed readings are in violation of the speed limit at the vehicle's present location. For claim 17, Petitioner relies on Wendt in combination with Tegethoff, Awada, and Evans. Wendt and Evans together in combination with Tegethoff and Awada seemingly cures the above-noted deficiency of Tegethoff and Awada with regard to independent claim 10, and of Tegethoff, Awada, and Evans with respect to claim 14. That is because Wendt teaches the desirability of a rotatably moveable structure to indicate the speed limit.

The combined teachings of Tegethoff, Awada, Evans, and Wendt appears to account for all of the features of claim 17. Accordingly, there is a reasonable likelihood that Petitioner would prevail on its assertion that claim 17 would have been obvious over Tegethoff, Awada, Evans, and Wendt under 35 U.S.C. § 103.

Because claim 17 depends on claim 14 which depends on claim 10, and because dependent claims include all of the features of the claims on which they depend, Petitioner also has shown a reasonable likelihood that it would prevail on demonstrating that claims 10 and 14 would have been obvious over the combined teachings of Tegethoff, Awada, Evans, and Wendt. We recognize that Petitioner did not specifically articulate a ground of unpatentability against claims 10 and 14 based on Tegethoff, Awada, Evans, and Wendt. However, we exercise discretion to recognize that the assertion was implicitly made by Petitioner's alleging that claim 17 would have been obvious over Tegethoff, Awada, Evans, and Wendt.

For claims 1-9, 11-13, 15, 16, and 18-20, we have not considered the ground of obviousness under 35 U.S.C. § 103, based on the combined teachings of

Tegethoff, Awada, Evans, and Wendt, and take no position in that regard. In this petition, that ground of obviousness has not been asserted by Petitioner against those claims, either expressly or by implication.

C. The alleged grounds based in whole or in part on Tokunaga

According to Petitioner, Tokunaga discloses each and every element of independent claim 1. There are two problems with that assertion.

The first still relates to that same limitation which undermines the anticipation assertion based on Aumayer and on Tegethoff, *i.e.*, that the speedometer is “integrally connected” to the colored display. Petitioner points out that Tokunaga discloses that its lighting unit is incorporated into the game machine so as to illuminate the liquid crystal display, and that in lieu of the gaming device the lighting unit has other applications, for example, for providing illumination to the surface of a vehicle speedometer. (Petition 23:16-21). On that basis alone, Petitioner concludes that the “integrally connected” limitation is met. We disagree.

Tokunaga provides no specific description of how the lighting unit would be attached to the display surface of a vehicle speedometer or if it is even attached. And even in the context of a game machine, Tokunaga describes that liquid crystal display panel 3 is disposed on top of the light guide plate 1 to permit the content of the liquid crystal display to be irradiated with light sent from the light guide plate 1, and that under the light guide plate 1 there is an electronic circuit board 4 for operating the liquid crystal display panel. (Tokunaga 2:66 to 3:5). That is not a specific description of how the light guide plate 1 is put in position relative to liquid crystal display panel 3. It is known only that light guide plate 1 is incorporated into the overall game machine, that the liquid crystal display 3 is disposed on one side of the light guide plate 1 and the electronic circuit board is disposed on the opposing side as shown in Figure 2.

Secondly, claim 1 requires a colored display to delineate which speed readings are in violation of “the speed limit at a vehicle’s current location.” Tokunaga does state that in the case of application to a vehicle speedometer, the color of the display light for the speedometer can be changed from blue to red if the vehicle speed exceeds a legal speed limit. (Tokunaga 5:1-5). But it does not describe that the legal speed limit it refers to is associated specifically with the current location of the vehicle. Petitioner has pointed to no description that the referenced speed limit is location-based.

Accordingly, there is a not reasonable likelihood that Petitioner would prevail on its assertion that claim 1 is anticipated by Tokunaga under 35 U.S.C. § 102(b).

As compared to claim 1, independent claim 10 adds the requirement of a global positioning system receiver which outputs signals to the display controller which adjusts the display to continuously update the delineation of which speed readings are in violation of the speed limit at the vehicle’s current position. For that limitation, Petitioner relies on the teachings of Hamamura, in combination with that of Tokunaga. However, reliance on Hamamura does not cure the above-noted deficiency of Tokunaga with regard to the “integrally attached” requirement for the speedometer and the colored display.

Because it depends on claim 1, claim 20 also includes the requirement that the speedometer is “integrally connected” to the colored display. As noted above, however, with respect to that limitation, Petitioner’s reliance on Hamamura does not cure the deficiency of Tokunaga.

In any event, Petitioner’s reliance on Hamamura to account for the limitation of continuous updating the delineation of which speed readings are in violation of the speed limit at the vehicle’s current location is misplaced because Petitioner’s

analysis of Hamamura equates “safe speed” at a location with the speed limit at that location. In the context of Hamamura, that is clearly not the case. Hamamura discloses determining a safe speed for a vehicle location based on the speed limit for that location, road shape “and the like” of each road. (Hamamura 3:[0008]). Hamamura discloses displaying the “safe speed” at the vehicle’s current location (Hamamura 1:[Constitution]:3-4) and states that the legal speed limit of a road on which the vehicle is currently running may not agree with a speed at which the vehicle can actually run safely. (Hamamura 3:[0004]:12-14).

There is a not reasonable likelihood that Petitioner would prevail on its assertion that claims 10 and 20 would have been obvious over Tokunaga and Hamamura under 35 U.S.C. § 103.

CONCLUSION

Petitioner has demonstrated a reasonable likelihood of prevailing on its challenge of claims 10, 14, and 17 of the ’074 Patent as obvious under 35 U.S.C. § 103 (1) over Aumayer, Evans, and Wendt, and (2) over Tegethoff, Awada, Evans, and Wendt.

Petitioner has not demonstrated a reasonable likelihood of prevailing on its challenge of any other claim on any ground.

Order

It is

ORDERED that the Petition is *denied* as to claims 1, 2, 6, 7, 8, 9, 10, 11, 12, 13, and 18-20 of the ’074 patent on the alleged ground of anticipation by Aumayer under 35 U.S.C. § 102(e);

FURTHER ORDERED that the Petition is *denied* as to claims 1, 2, 6, and 7 of the ’074 patent on the alleged ground of anticipation by Tegethoff under 35 U.S.C. § 102(b);

FURTHER ORDERED that the Petition is *denied* as to claim 1 of the '074 patent on the alleged ground of anticipation by Tokunaga under 35 U.S.C. § 102(b);

FURTHER ORDERED that the Petition is *denied* as to claims 3-5 and 14-16 of the '074 patent on the alleged ground of obviousness over Aumayer and Evans under 35 U.S.C. § 103;

FURTHER ORDERED that the Petition is *granted* as to claims 10, 14, and 17 of the '074 patent on the alleged ground of obviousness over Aumayer, Evans, and Wendt under 35 U.S.C. § 103;

FURTHER ORDERED that the Petition is *denied* as to claims 3-5 on the alleged ground of obviousness over Tegethoff and Evans under 35 U.S.C. § 103;

FURTHER ORDERED that the Petition is *denied* as to claims 8-13 and 18-20 on the alleged ground of obviousness over Tegethoff and Awada under 35 U.S.C. § 103;

FURTHER ORDERED that the Petition is *denied* as to claims 14, 15, and 16 on the alleged ground of obviousness over Tegethoff, Awada, and Evans under 35 U.S.C. § 103;

FURTHER ORDERED that the Petition is *granted* as to claims 10, 14, and 17 on the alleged basis of obviousness over Tegethoff, Awada, Evans, and Wendt under 35 U.S.C. § 103;

FURTHER ORDERED that the Petition is *denied* as to claims 10 and 20 on the alleged ground of obviousness over Tokunaga and Hamamura under 35 U.S.C. § 103;

FURTHER ORDERED that pursuant to 35 U.S.C. § 314(a), a trial for inter partes review of the '074 patent is hereby instituted, commencing on the entry date

IPR2012-00001
Patent 6,778,074

of this Order, and pursuant to 35 U.S.C. § 314(c) and 37 C.F.R. § 42.4, notice is hereby given of the institution of trial;

FURTHER ORDERED that the trial is limited to the two above-stated grounds of obviousness directed to claims 10, 14, and 17, and that no other ground for any claim is authorized for trial; and

FURTHER ORDERED that an initial conference call with the Board is scheduled for **1 PM EST on January 23, 2013**; the parties are directed to the Office Trial Practice Guide, 77 Fed. Reg. 48756, 48765-66 (Aug. 14, 2012) for guidance in preparing for the initial conference call, and should come prepared to discuss any proposed changes to the Scheduling Order entered herewith and any motions the parties anticipate filing during the trial.

IPR2012-00001
Patent 6,778,074

For PETITIONER:

Jennifer C. Bailey
HOVEY WILLIAMS LLP
jcb@hoveywilliams.com

For PATENT OWNER

John R. Kasha
Kasha Law LLC
john.kasha@kashalaw.com

Cabrach J. Connor
Reed & Scardino LLP
cconnor@reedscardino.com